



# RAEGuard 2 PID



---

User Guide

---

P/N: H-D03-4001-000  
Rev M February 2018

# RAEGuard 2 PID User's Guide

## Contents

### Section 1: RAEGuard 2 PID User's Guide

1	General Information .....	6
2	General Specifications.....	8
2.1	RAEGuard 2 PID Specifications .....	8
2.2	Proper Product Disposal At End Of Life.....	9
3	Operation .....	10
4	Physical Description.....	11
5	Physical Dimensions .....	11
6	Installation and Access Instructions .....	12
6.1	Mounting .....	12
6.2	Instrument Disassembly .....	14
6.3	Electrical Wiring .....	15
6.4	Wiring Procedure.....	16
6.5	Earth Grounding Instructions .....	17
6.5.1	External Earth Grounding.....	17
6.5.2	Internal Earth Grounding.....	17
6.5.3	Finished Grounding Wires .....	18
6.6	Alarm Contact Setup .....	18
7	Display And User Interface .....	20
7.1	User Interface .....	20
7.2	Magnet Key .....	20
7.3	Using The Magnet Key .....	21
7.4	System Initialization.....	21
7.5	Reading Display .....	21
7.6	Instrument Status Display.....	22
8	Navigating Settings .....	23
9	Programming Menus .....	27
	Zero/Fresh Calibration.....	27
	Meas. Unit* .....	27
	High Alarm.....	27
	Temp. Unit.....	27
	Span Calibration .....	27
	Meas. Range* .....	27
	Low Alarm.....	27

## RAEGuard 2 PID User's Guide

---

Language .....	27
Set Span Value .....	27
Meas. Gas* .....	27
Ext. Alarm Delay* .....	27
Pump Duty (%)* .....	27
Calibration Type* .....	27
Pump Cycle(s)* .....	27
Calibration Gas* .....	27
Pump Status* .....	27
Bus Baudrate .....	27
Analogout 4mA .....	27
Analogout 20mA.....	27
Unit ID.....	27
LCD Contrast.....	27
LCD Backlight.....	27
Change Password*.....	27
9.1 Entering Programming Mode .....	28
9.2 Calibration .....	29
9.3 Measurement (Advanced Mode) .....	32
9.4 Alarm Setting.....	35
9.5 Monitor Setup.....	37
10 Calibration .....	43
10.1 Zero Calibration.....	44
10.2 Span Calibration .....	46
11 Alarm Signal Summary .....	48
12 Maintenance .....	50
13 DigiPID Sensor Module Replacement .....	50
14 Troubleshooting.....	52

### SECTION 2: DigiPID User's Guide

SAFETY INSTRUCTIONS .....	54
15 Read Before Operating .....	55
15.1 DigiPID Marking.....	56
15.2 Operation Area and Conditions .....	57
15.2.1 Hazardous Areas classified by Zones.....	57
15.2.2 Hazardous Areas classified by Divisions .....	57

## RAEGuard 2 PID User's Guide

---

15.3	Instruction For Safe Use .....	57
15.4	Use In Hazardous Areas .....	58
15.5	Year of manufacture .....	58
15.6	Specifications .....	59
16	General Information .....	60
17	Grounding (Earth Connection) .....	61
18	Physical Description .....	62
19	Sensor Parts And Dimensions .....	63
20	Operating the Sensor Module .....	64
20.1	Preparing The Sensor For Use .....	64
21	Using The Sensor Module .....	65
21.1	Gas Flow Routing Connection .....	65
21.2	Sensor Module Calibration .....	66
21.3	Maintenance And Calibration .....	68
21.4	Replacing the Lamp And Filter .....	68
22	Replacing The Sensor's Teflon UV Shield .....	70
23	Sensor & Lamp Cleaning/Replacement .....	73
23.1	Cleaning The PID Sensor .....	73
23.2	Cleaning The Lamp Housing Or Changing The Lamp .....	74
23.3	Cleaning The Instrument .....	75
23.4	Ordering Replacement Parts .....	75
23.5	Special Servicing Note .....	75
24	Electronic Waste Disposal .....	76
25	Appendix A: Range, Sensor and Related Configuration .....	77
26	ModBus/RS-485 Information .....	77
27	Appendix B: Controlled Section .....	79
27.1	Scope .....	79
27.2	Contents .....	79
27.3	Scope .....	81
27.4	Responsibility .....	81
27.5	Contents .....	81
28	Technical Support .....	89
29	Honeywell Analytics Contacts .....	89

## RAEGuard 2 PID User's Guide

---

© Honeywell International ©2018. All Rights Reserved.

This document is the confidential and proprietary information of Honeywell. Reproduction and distribution of these materials without the express written consent of Honeywell is strictly forbidden. While this information is presented in good faith and believed to be accurate, Honeywell disclaims the implied warranties of merchantability and fitness for a purpose and makes no express warranties except as may be stated in its written agreement with and for its customer.

In no event is Honeywell liable to anyone for any direct, special, or consequential damages. The information and specifications in this document are subject to change without notice.

These commodities, technology, or software were exported from the United States in accordance with the Export Administration Regulations. Diversion contrary to U.S. law prohibited.

This product may contain or be derived from materials, including software, of third parties. The third-party materials may be subject to licenses, notices, restrictions and obligations imposed by the licensor. The licenses, notices, restrictions and obligations, if any, may be found in the materials accompanying the product, in the documents or files accompanying such third party materials, in a file named third-party licenses on the media containing the product, or at <http://www.honeywell.com/ps/thirdpartylicenses>.

Honeywell, RAEGuard 2 PID, and DigiPID are U.S. registered trademarks of Honeywell International Inc. Other brand or product names are trademarks of their respective owners.

# RAEGuard 2 PID User's Guide

---

## Section 1: RAEGuard 2 PID User's Guide



### 1 General Information

The RAEGuard 2 PID is a fixed photoionization detector (PID) that measures a broad range of volatile organic compounds (VOCs). It operates on 10 to 28 VDC and provides an analog (4-20mA) three-wire signal output, and RS-485 Modbus digital signal output.

RAEGuard 2 PID uses an intelligent processing platform and digital sensor technology, supports multiple ranges and resolutions, and can perform off-line calibration and environmental self-adaptation.

RAEGuard 2 PID has a graphic display and local sound alarm and light status indicator. A magnetic key interface enables the detector to be calibrated and operational parameters adjusted with the explosion-proof enclosure in place. In addition, the PID module can be easily removed in hazardous locations for calibration or maintenance.

#### Key features:

- Digital Smart Sensor Technology
- Three wires, supports 4-20mA analog output
- Operates in flow-through mode and can be used in most environments
- RS-485 digital communication in ModBus protocol
- Explosion-proof stainless-steel enclosure for hazardous environment applications
- Magnetic-key interface eliminates the need to open the explosion-proof housing when adjusting parameters.
- Matrix LCD of 128x64 supports graphic display
- LED alarms when High or Low alarm point is reached
- Operation at 10 to 28 VDC
- Three dry contacts (<30V, 2A) normally open (or normally closed), one for High and Low alarm, another for Fault alarm

# RAEGuard 2 PID User's Guide

---

## Applications:

- Refineries, petrochemical and natural gas plants
- Metallurgical
- Chemical, medication
- Environmental protection
- Electricity, communications
- Fire protection
- Utilities
- Pulp and paper, printing
- Storage
- Sewage disposal
- Food, brewing
- Scientific research, education, homeland security

## Hazardous Location Classification:

ATEX	⊕ II 2 (1) G Ex db [ia Ga] IIC T4 Gb
UL/CSA	Class I, Div. 1, Groups A B C D T4
IECEX	Ex db [ia Ga] IIC T4 Gb
TR CU	1Ex d [ia Ga] IIC T4 Gb X





# 2 General Specifications

## 2.1 RAEGuard 2 PID Specifications

<b>Basic Parameters</b>	
Principle	PID (photoionization detector)
Sensor	Digital Smart Sensor
Sampling	Internal diaphragm pump
Working Current	DC 10 to 28V, 210mA at 24V
Power	<5W
Output	<ul style="list-style-type: none"> <li>• 4-20mA</li> <li>• Three-level programmable alarm relays (30 VDC, 2A)</li> <li>• RS-485 (Supports Modbus)</li> </ul>
IP Rating	IP-65
Mechanical Interface	3/4" NPT Male
Installation	2" pipe-holding or wall mounting
User Interface	Three-key magnetic bar adjustment
Calibration	Two or three points
<b>Environmental Parameters</b>	
Temperature	-20° C to +55° C (-4° F to 131° F)
Humidity	0 to 95% relative humidity, non-condensing
Pressure	90 to 110kPa
<b>Display</b>	
Display	128x64 matrix backlit LCD, supports graphic display

## RAEGuard 2 PID User's Guide

### *RAEGuard 2 PID Specifications (continued)*

<b>Physical Parameters</b>	
Dimensions, L x W x H	257 x 201 x 107 mm (10.1" x 7.9" x 4.2")
Material	Stainless steel
Weight	3.5 kg (7.7 lbs)
<b>Certification</b>	
ATEX	Ⓔ II 2 (1) G Ex db [ia Ga] IIC T4 Gb
UL/CSA	Class I, Div. 1, Groups A B C D T4
IECEX	Ex db [ia Ga] IIC T4 Gb
TR CU	1Ex d [ia Ga] IIC T4 Gb X
Ex Entity Parameters	Um: 28VDC (input supply)

Sensor Specifications: See DigiPID sensor section on page 59.

## 2.2 Proper Product Disposal At End Of Life



The Waste Electrical and Electronic Equipment (WEEE) directive (2012/19/EU) is intended to promote recycling of electrical and electronic equipment and their components at end of life. This symbol (crossed-out wheeled bin) indicates separate collection of waste electrical and electronic equipment in the EU countries. This product may contain one or more Nickel-metal hydride (NiMH), Lithium-ion, or Alkaline batteries. Batteries must be recycled or disposed of properly.

At the end of its life, this product must undergo separate collection and recycling from general or household waste. Please use the return and collection system available in your country for the disposal of this product.

### 3 Operation

The calibration of all newly purchased Honeywell Analytics instruments should be tested by exposing the sensor to a known concentration calibration gas before the instrument is used or put into service. Prior to factory shipment, the RAEGuard 2 PID is calibrated and tested. However, the user should calibrate the instrument before the first use.

**Kit Accessories include:** RAEGuard 2 Magnet Key, and User's Guide.

### 4 Physical Description

The RAEGuard 2 PID can be easily installed and integrated with various control systems. It is designed with flexible pipe-holding/wall-mounting options and standard connection terminals.

### 5 Physical Dimensions

The physical dimensions are as shown:

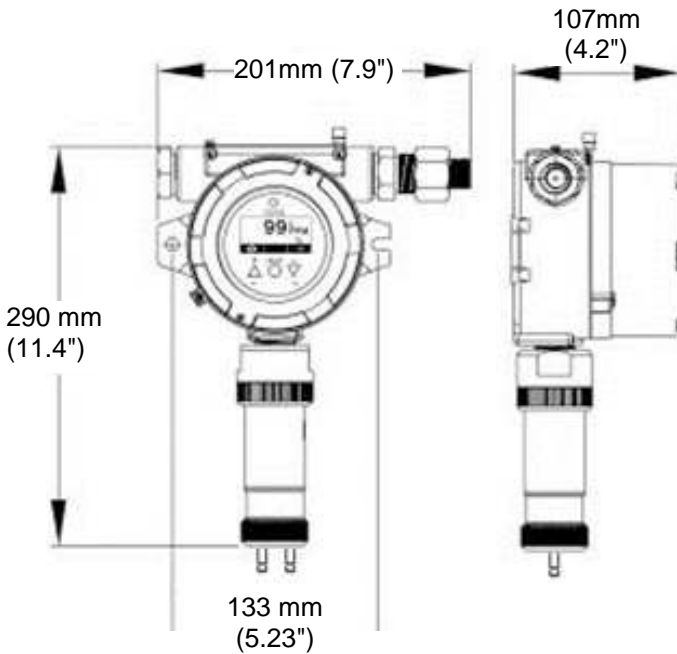

## 6 Installation and Access Instructions

### WARNING

1. To prevent ignition of hazardous atmospheres, area must be free of flammable vapors and supply circuit must be disconnected before removing cover.
2. For European application, the installation must comply with the requirements of EN 60079-14.

### 6.1 Mounting

First, decide where the transmitter will be mounted. (Refer to installation drawing, below.) Drill two holes in mounting surface, with the center of the holes 5.25" (133mm) apart.

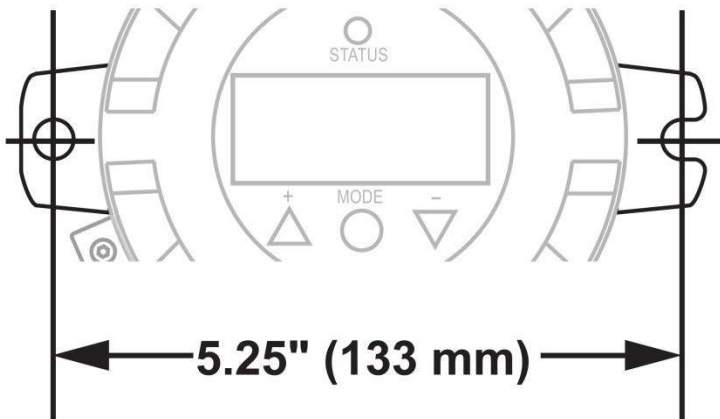

Besides directly mounting the RAEGuard 2 PID to a wall, it can be mounted on a pipe.

## RAEGuard 2 PID User's Guide

**Note:** When installing the RAEGuard 2 PID, make sure the sensor is vertically oriented (pointing straight down). Also, make sure the water-trap filter is connected to the gas inlet labeled “IN” (the longer of the two inlets). **Note:** Only operate the RAEGuard 2 PID in a non-condensing environment.

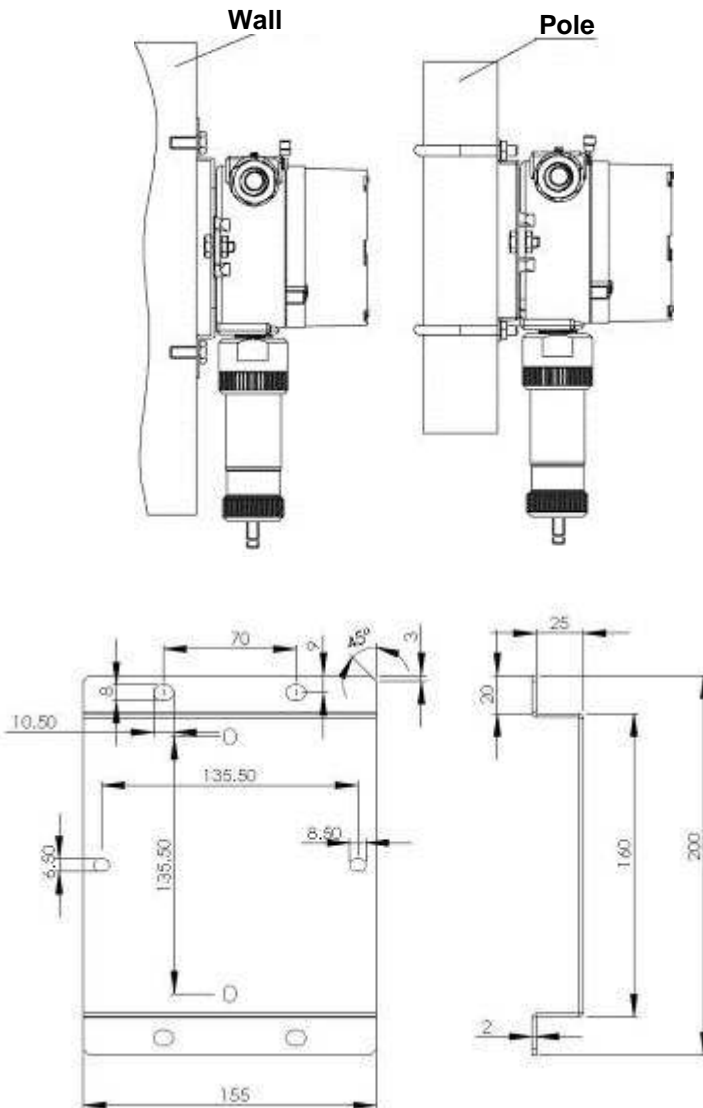

## RAEGuard 2 PID User's Guide

### 6.2 Instrument Disassembly



Prior to service: Make sure power is OFF. Observe all Hazardous Location Safety procedures.



1. Loosen the fastening bolt before unscrewing the housing lid. Unscrew the housing lid from the housing body by rotating it counterclockwise. (As shipped, one of the conduit holes is covered by the provided hex-head plug. The other conduit is for wire connections.)



2. Pull off the retaining clip to release the instrument assembly.



3. Tilt the instrument assembly 90°.
4. Unlock the 24-pin connector on the ribbon cable.
5. Lift the entire instrument assembly out of the housing.
6. Unscrew the sensor by turning it counterclockwise.



**Disassembled instrument.**

## RAEGuard 2 PID User's Guide

To reassemble the instrument:

- 1 Reconnect the 24-pin connector of the ribbon cable and lock it in place.
- 2 Fasten the cable to the board.
- 3 Mate the board with the clip on the left side and tilt it over.
- 4 Click the board into place.
- 5 Screw on the sensor, making sure not to block the gas inlet hole and connectors.
- 6 Screw on the housing top.
- 7 Screw down the fastening bolt.

### 6.3 Electrical Wiring

The detector connects to peripheral equipment via three terminal blocks. These blocks accept 12AWG to 24AWG wire (0.2 to 4.0 mm<sup>2</sup>).

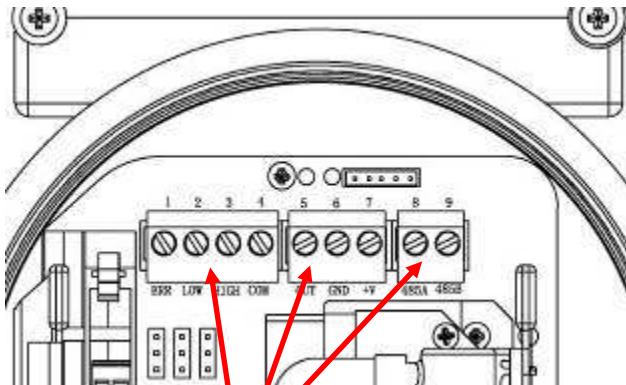

**Terminal blocks**



# RAEGuard 2 PID User's Guide

## 6.4 Wiring Procedure

1. Inside the housing bottom, unplug the two green terminal block plugs from the terminal block on the PC boards.

**Note:** The terminal block plugs accept 12 AWG to 24 AWG wire.

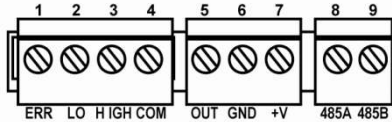

2. Lace the wires through the RAEGuard 2 PID's wire hole(s) and connect wires to the corresponding pin numbers of the terminal blocks:

Terminal	Terminal Definition	Terminal description	No.
Block 1	Failure Alarm Contact	ERR	1
	Low Level Alarm Contact	LOW	2
	High Level Alarm Contact	HIGH	3
	Switch signal Common Contact	COM	4
Block 2	4-20 mA Output	OUT	5
	Power Supply Negative	GND	6
	Power Supply Positive	+V	7
Block 3	RS485A terminal	485A	8
	RS485B terminal	485B	9

## 6.5 Earth Grounding Instructions

### 6.5.1 External Earth Grounding

Fasten the crimped ground wire with hardware as illustrated below. The wire should have a minimum cross-section area of  $4\text{mm}^2$  for its conductor.

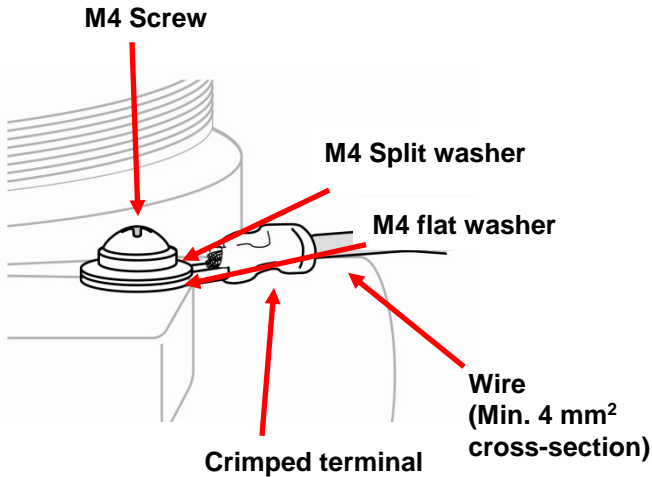

### 6.5.2 Internal Earth Grounding

Use the same hardware as shown in the illustration of external earth grounding. The wire should be no less than the size of the power lines. Signal grounding can connect to a cable's shielding layer if shielded cable is used. If a separate wire is used for grounding, its cross section should be greater than that of the power line.

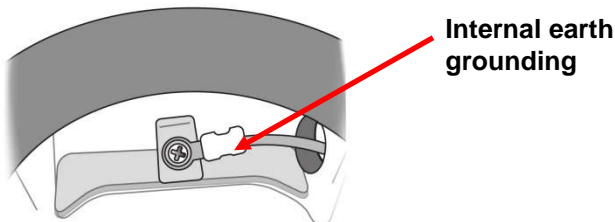

## RAEGuard 2 PID User's Guide

### 6.5.3 Finished Grounding Wires

Internal and external grounding are shown here, as well as an alternate external grounding point. Always follow local electrical guidelines.

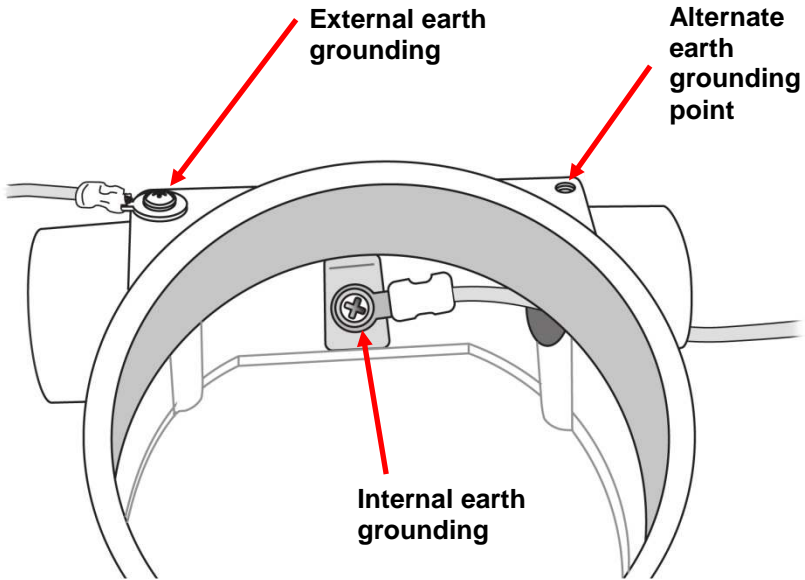

## 6.6 Alarm Contact Setup

The alarm contacts can drive external alarms such as a light or buzzer. By default, the three relays are set for normally open (NO) operation, meaning that contact is closed when in alarm.

You can separately change each relay from normally open to normally closed (NC) operation by changing the position of the jumpers on the internal printed circuit board.

## RAEGuard 2 PID User's Guide

Three jumper blocks are located below the three green terminal blocks. They are labeled (from left to right): J4, J3, and J1. Here are their functions:

Jumper	Function
J1	High
J3	Low
J4	Error

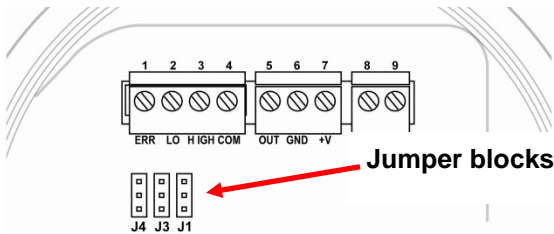

Lift off the jumper for each one that you want to change and slide it back on, either connecting the middle and top points or middle and bottom points.

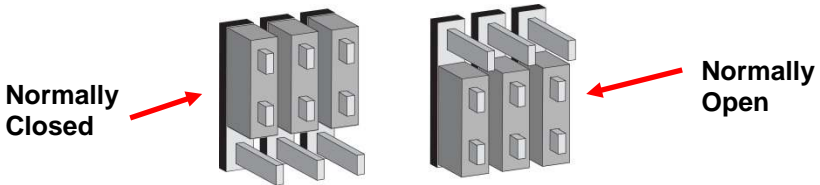

### Important!

Once the system is operational, test the functionality of all three relays.

**Note:** The relays may be disabled based on the sensor that is attached to the RAEGuard 2 PID. Certain sensors, such as the 1-1000 ppm DigiPID, disable the correction factor library and relays of the RAEGuard 2 unit. Users who require these functions should use the 0.1-1000 ppm DigiPID sensor module.

## 7 Display And User Interface

### 7.1 User Interface

The RAEGuard 2 PID's user interface consists of a status LED, an LCD display, and three keys, [+], [MODE], and [-]. The three keys are operated by using the Magnet Key.

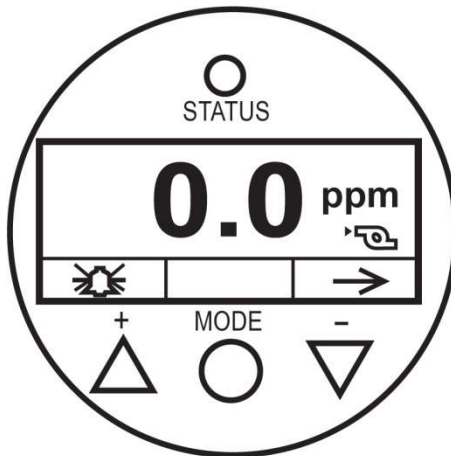

RAEGuard 2 PID user interface.

### 7.2 Magnet Key

The RAEGuard 2 PID has no external switches, but instead uses the magnetic end of the RAEGuard Magnet Key (p/n 033-3032-000) to activate switches built into the unit.

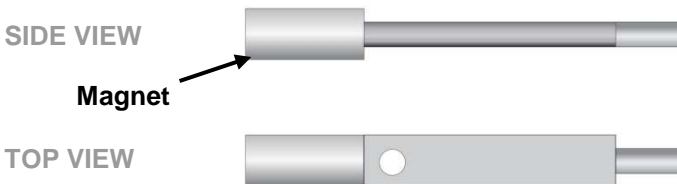

## RAEGuard 2 PID User's Guide

---

### 7.3 Using The Magnet Key

Using the magnet end of the Magnet Key, briefly touch the glass above the MODE circle or the triangles labeled [+] and [-]. Then remove the key straight out and away from the RAEGuard 2 PID.

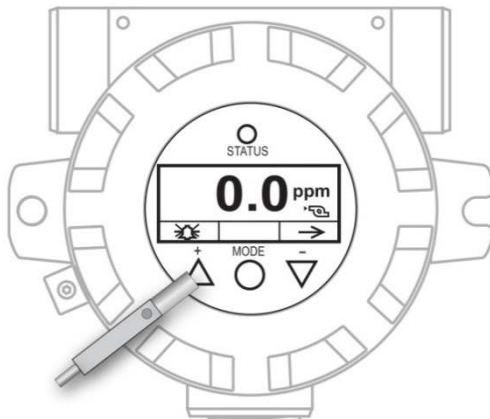

**RAEGuard Magnet Key touching glass above the [+] triangle.**

**Important!** Never drag the key sideways, or two functions may be activated.

### 7.4 System Initialization

When the RAEGuard 2 PID's system power is turned on, it initializes and a Honeywell logo appears on the display. As the transmitter is warming up, each component is checked. The countdown timer appears on the screen for the warm-up.

### 7.5 Reading Display

As the transmitter enters the Reading Display, it automatically starts testing for errors and goes through a cycle of checking each alarm condition. If there are no errors or alarm conditions, the green "OK" LED is lit and the gas concentration is displayed.



## RAEGuard 2 PID User's Guide

If there is an error, the “Fault” LED blinks and an error message blinks. Each alarm condition has a corresponding LED that blinks an amber color when the readings are outside a specified range or limit.

### 7.6 Instrument Status Display

After warm-up, the detector enters the Status Display. It automatically starts testing for errors and goes through a cycle of checking each alarm condition. If there is no error message or alarm condition, gas concentration is displayed and LED flashes green.

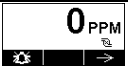
If there is an error or alarm, a corresponding message shows on the screen, and the LED indicates different statuses:

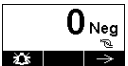
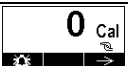
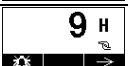
Status	External Alarm	LED	LCD	Output Current
Normal	-	Green	Reading	Reading
Low alarm Alarm Limit	LOW	Red flashing, 2 Hz	Reading	Reading
High alarm Alarm Limit	HIGH	Red flashing, 3 Hz	Reading	Reading
Over Range	HIGH	Red flashing, 3 Hz		22mA
Pump Error	ERR	Yellow flashing, 1 Hz		2mA
Lamp Error	ERR	Yellow flashing, 1 Hz		2mA
Sensor Negative Drift	--	Yellow flashing, 1 Hz		2mA
Calibration Fault	ERR	Yellow flashing, 1 Hz		2mA
Humidity Sensor Fault	ERR	Green, 1 Hz		Reading